

SENSOR MUT1222

Electromagnetic Flowmeter

Technical Guide W8.2



Application

Water network management

Leakage control

District metering

Flow surveys

Flow profiling

Checking on-site flowmeters

Data capture reporting and analysis

Approvals/Standards

GSM ready

IEC approved

EX approved

We are the supply partner of choice for New Zealand's civil construction industry, specialising in water and infrastructure based solutions.

Sensor MUT1222

A COST-EFFECTIVE ALTERNATIVE TO FULL-BORE METERS

EUROMAG INTERNATIONAL presents the new MUT1222 electromagnetic insertion flowmeter in three different sizes (small, medium and large) suitable to use in pipe sizes from DN 50 to 2600.

Delivering highly accurate bi-directional measurement for water distribution and raw water pipelines, it is robust, and has no moving parts, this allows it to be reliable and suitable to measure a wide range of flows.

The MUT1222 can be used as a portable or a dedicated / permanent instrument; with its "hot tapping" application it is very easy and quick to install with no need to stop the flow under full working pressure conditions.

It is an alternative solution to full bore metering and with its compact size allows installation on small pipes, providing water monitoring in applications considered impossible.

Applications:

- Water network management
- Leakage control
- District metering
- Flow surveys
- Flow profiling
- Checking on-site flowmeters
- Data capture reporting and analysis

Installation:

- Compact with converter MC608A/B/R
- Compact Vertical with MC406
- Separate (remote)with MC608A/B/R and MC406 with cables supply from factory (up to 30mt for battery powered, 100mt for mains powered version)



Equipment:

- 1" ball valve zinc plated brass
- "Hot tap" installation
- Head of the unit in POM 22mm
- Valve connection (female-female)
- Probe 12mm
- Pressure up to 20 bar
- Input connection for pressure gauge
- Handle grips with flow directions
- Body in AISI304
- 2 Electrodes in AISI316L
- ATEX on request (only separate version)

Reference standards

The Euromag magnetic meters are marked CE and are manufactured according to the following standards:

- 2014/35/EU - EN 61010-1:2013 (LVD)
- 2014/30/EU - EN 61326-1:2013 (EMC)
- 2014/34/UE - IEC 60079 - 0, IEC 60079 - 18 (ATEX - IECEx) Separate version

Temperature of liquid:

- 80° compact and separate version



Technical features:

Size range	Size Small (S)	Size Medium (M)	Size Large (L)
		50...600	200...1500
Available electrodes [*]	AISI 316L		
Body material	AISI 304 Stainless Steel		
Head of sensor	POM		
Standard operating pressure	20 bar		
Temperature of liquid	-40 °C , +80 °C		
Protection Degree	IP68 for immersion at 1,5m (IEC 529)		
Converter compatibility	MC608, MC406		
Parts in contact with liquid	Head of sensor	Electrodes	Pipe end
	POM	AISI 316L	AISI 304
Electric connections	Cable gland M20 x 1.5 + Terminal block + sealing resin		

Advantages:

- No moving parts
- No pressure loss
- Long lasting stability and precision
- No filter needed, zero maintenance
- Extremely sturdy structure
- Internal parts protected by a bi-component resin in order to increase protection from external agents
- Bi-directional measure



Optional transport case

Calibration and maximum error

Each sensor is calibrated on a hydraulic test rig equipped with a ISO17025 traceable weighing system. The accuracy is equal to 2% +/- 2 mm/s. Bi-directional measure.

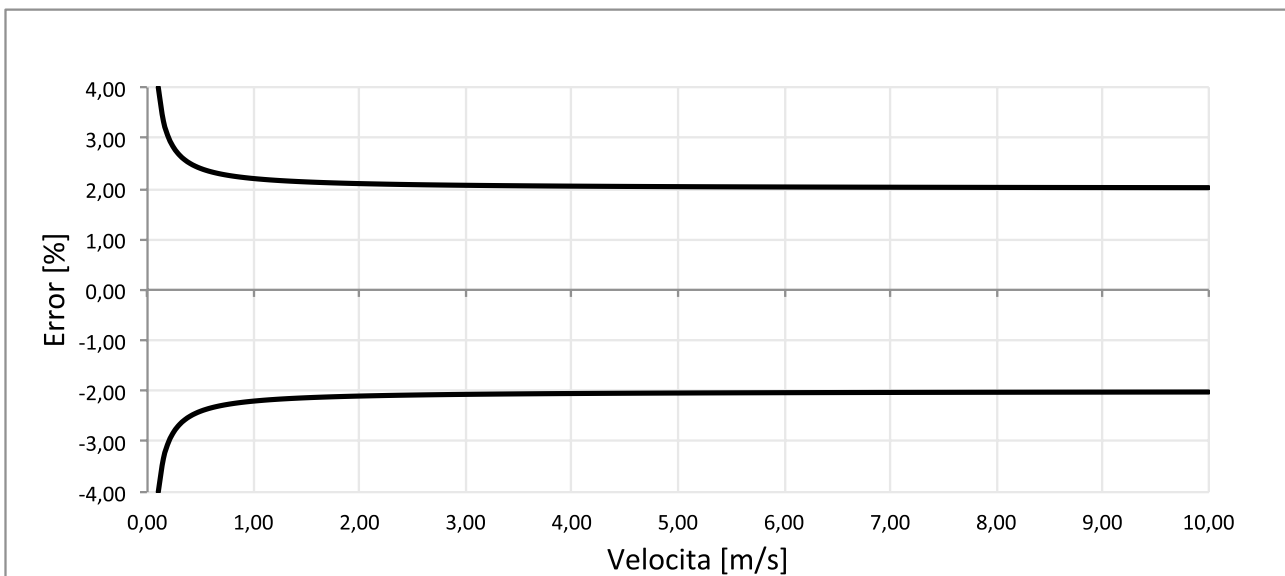

- D:** Internal diameter
- S:** Pipe wall thickness (lining included)
- B:** Dead length
- H:** Housing dimension
- Ltot:** Instrument length
- ES:** Standard dimension (Euromag original parts)
- I:** Insertion depth = $D/8$
- M1:** Insertion control dimension

M1 = $L_{tot} - S - (D/8)$

Size S:

$M1 = 403 - S - (D/8)$

Size M:

$M1 = 674 - S - (D/8)$

Size L:

$M1 = 916 - S - (D/8)$

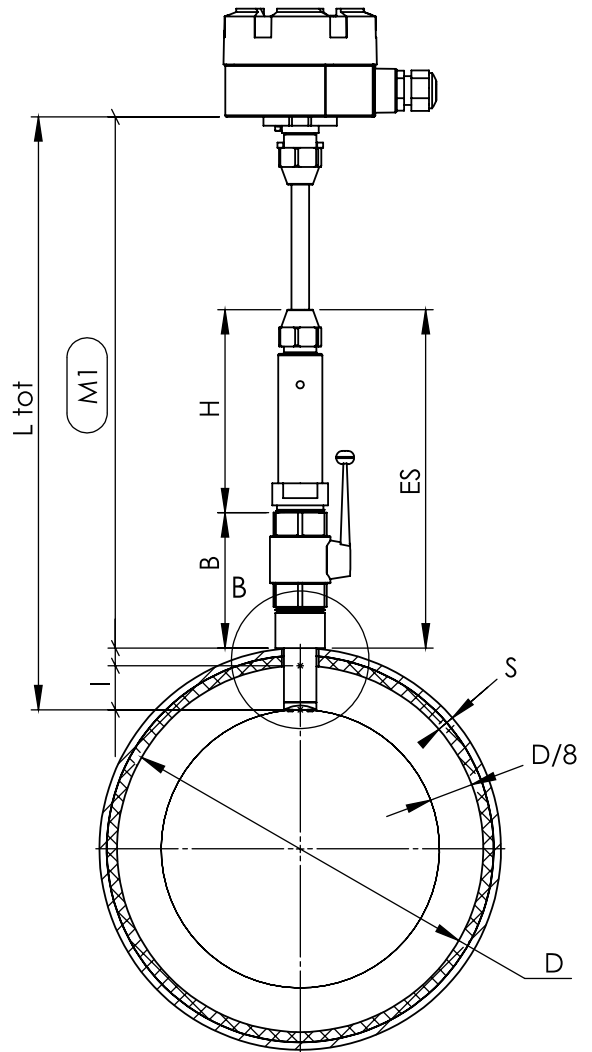

DETAIL B

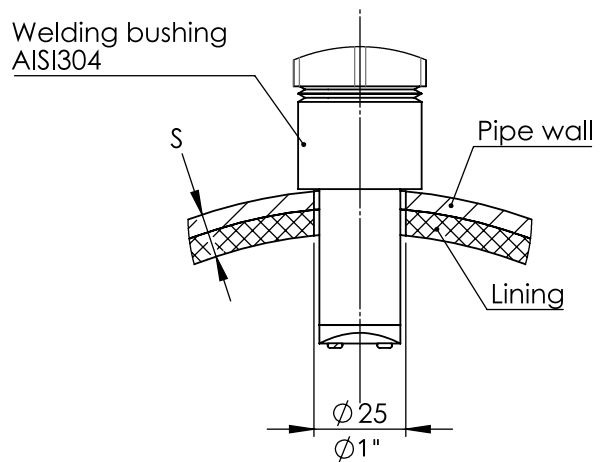

Size	Min Pipe Diameter		Max Pipe Diameter	
	DN	Inches	DN	Inches
S	50	2"	600	24"
M	200	8"	1600	64"
L	450	18"	2600	104"

Size S:

M1 = 403 - S - (D/8)

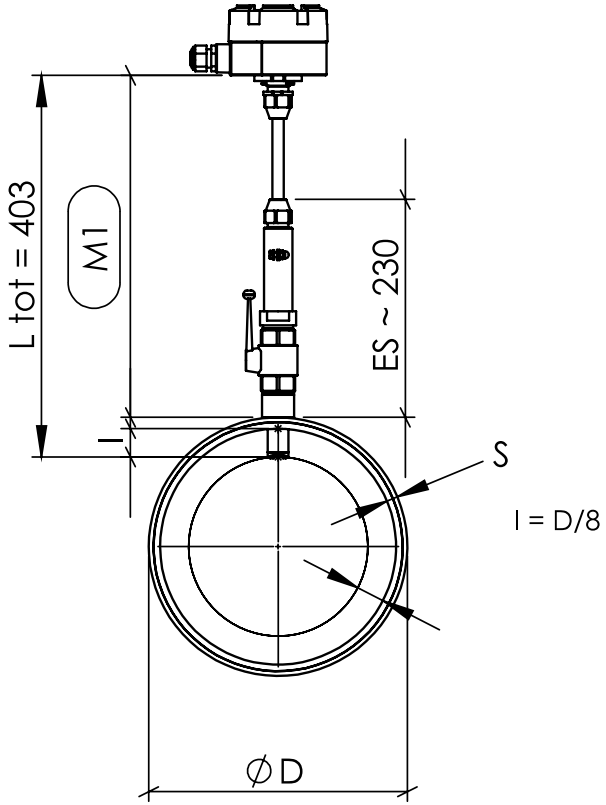

Size M:

M1 = 674 - S - (D/8)

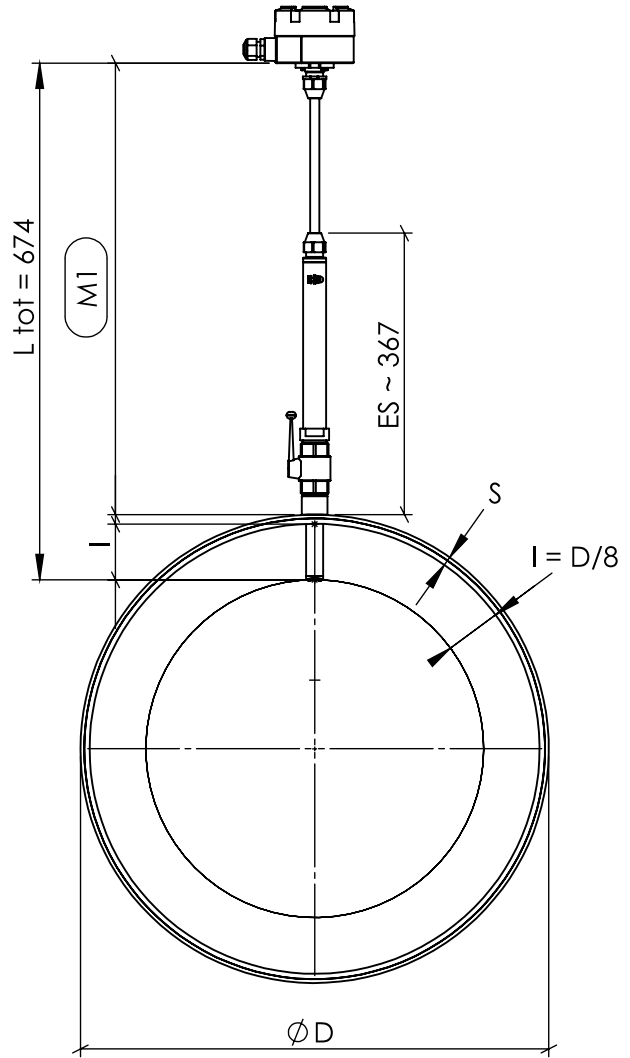

Size L:

M1 = 916 - S - (D/8)

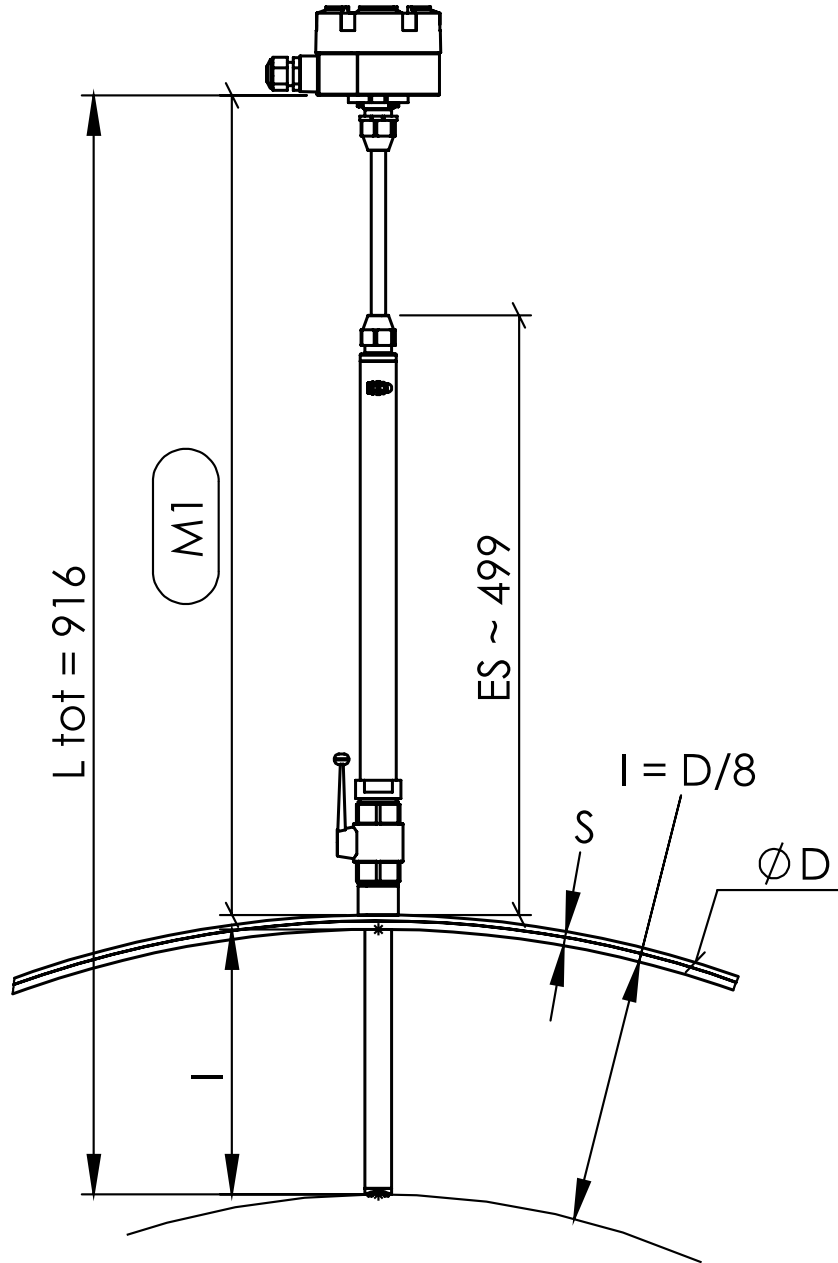

Branches Nationwide *Support Office & Technical Services 0800 93 7473*

Disclaimer: While every effort has been made to ensure that the information in this document is correct and accurate, users of Hynds product or information within this document must make their own assessment of suitability for their particular application. Product dimensions are nominal only, and should be verified if critical to a particular installation. No warranty is either expressed, implied, or statutory made by Hynds unless expressly stated in any sale and purchase agreement entered into between Hynds and the user.