



Technical Guide W8.13

Flostar M

Designed to meet the advanced needs of water utilities in large revenue collection applications

Engineered for reliability and built upon 20 years of industry-leading design, Itron's Flostar M is the best choice for drinking water metering in commercial and industrial applications.

FEATURES AND BENEFITS

- » Very wide dynamic range, MID-approved up to R630
- » Low flow accuracy
- » Peak flow capacity
- » Hermetically sealed register (IP68), orientable 360
- » Mobile flanges for ease of installation and resizing
- » Hermetically sealed register (IP68), orientable 360°
- » Body material in compliance with the new European Drinking Water requirement (4MS Approach)
- » Flostar M is not affected by flow disturbances generated by the most commonly seen hydraulic disturbers when they are placed directly upstream of the meter

Wide Measuring Range

Flostar M is a single jet meter available in sizes from DN 40 to 150. Its metrological performances far exceed ISO 4064:2014 standards.

Its low flow accuracy range combined with significant peak flow capacity ensure complete and efficient measurement whatever the faced flow-rates.

Reliability

Flostar M features a direct magnetic transmission between the turbine and the register without any intermediate gearing in the metered water.

This results in a very robust and reliable design able to withstand most types of potable water environments.

Ease of read in the toughest humid environments (ie: flooded pits) is secured by hermetically sealed IP68 register (copper can/mineral glass envelope).

Simple an effective

Simple but highly engineered materials and design enable a very long durability and the best performances for water metering.

Endurance & Peak Flow Resistance

Performance over time is a key requirement for efficient billing. Flostar M features a patented turbine ball pivoting enhancing endurance at low flow-rates. Hydrodynamic balance and turbine design bring resistance at high and peak flows.

- » Hermetically sealed register (coppercan/mineral glass envelope)
- » Patented ball pivot
- » Patented turbine levitation



Flostar M DN65

WORKING PRINCIPLE

Flostar M is a single jet meter. The water jet is canalized by an injector before hitting the turbine. The single jet tapered injector straightens the flow profile. Its large bore area prevents meter overspeed by clogging.

The high precision design of the inlet **1** allows Flostar M to meet best accuracy without the need for any bypass or calibration vane adjustment system. The turbine movement is directly transmitted to the extra dry register through a magnetic coupling **2** without the need for any intermediate gearing in the metered water.

This allows Flostar M to conserve its initial accuracy over time, under the most demanding service conditions of potable water networks.

High quality material for the turbine bearings and patented ball pivot **3** design allows detection of leakages initially and over time regardless of the flow profiles. The hermetically sealed copper can/mineral glass envelope of the IP68 register **4** is safeguarding the read and integrity of the indicator in the toughest environments (flooded pits, mechanical tampering attempts, ...). Flostar M is equipped with Mobile flanges; See Instructions of Installation Guide.

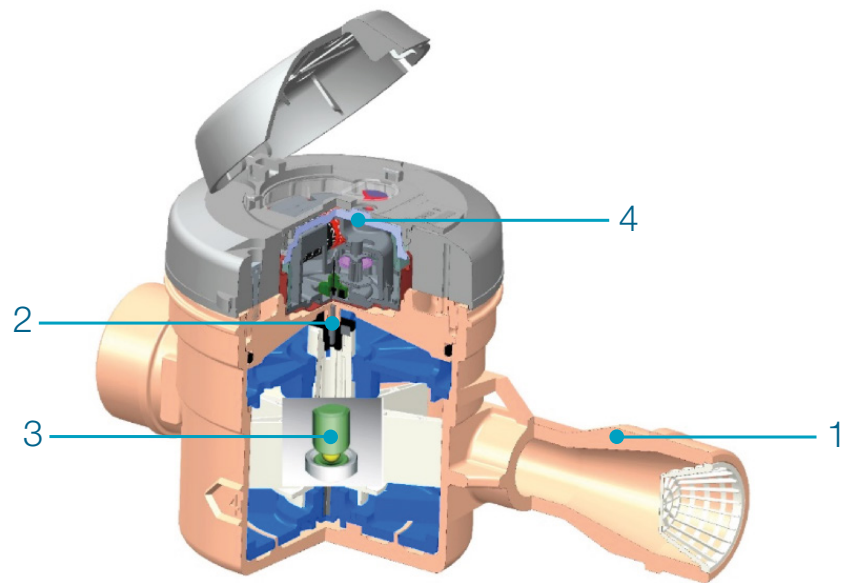

Flostar M DN40 3D Section

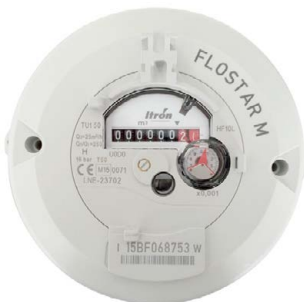

Flostar M indicator

COMMUNICATION : READY FOR SMART METERING

Flostar M is supplied pre-equipped with Cyble Target

Allows communication and remote reading through:

- » Pulse output (Cyble Sensor)
- » M-Bus protocol (Cyble M-Bus)
- » Radio frequency wireless link (Cyble RF)

These Cyble modules allow the Flostar M meter to be connected with various associated systems like our supervision system WaterMind (see specific leaflet). They are particularly adapted to commercial and industrial applications where a need for frequent meter monitoring is expressed especially in hard-to-read locations.

Key Advantages of Cyble Technology

- » No need for additional investment on the meter to implement remote reading
- » Itron standardized meter interface, irrespective of meter technology and widely spread on Itron water meters range
- » Reliable electronic switching (no wear or bouncing)
- » Reverse flow management
- » Field proven technology with a 25 years experience
- » Not affected by magnetic tampering



Cyble RF fitted on Flostar M

Metrological Characteristics

Mid Approval Certificate 23702								
ISO 4064/2014 LNE certificate 11564 rev 3								
OIML R49 Certificate 20586 7310		mm	40	50	65	80	100	150
Minimal flowrate	(Q1)	l/h	80	79	100	157	250	254
Transitional flowrate	(Q2)	l/h	160	127	160	252	400	406
Permanent flowrate	(Q3)	m³/h	16	25	40	63	100	160
Overload flowrate	(Q4)	m³/h	20	31,25	50	78	125	200
Approval ratio	(Q3/Q1)		200	315	400	400	400	630
Q2/Q1						1.6		
Accuracy class						2		
Temperature class		°C			T50			T30
Position					Horizontal			
Pressure Class					16			
Pressure loss Class					ΔP63			
Maximum Admissible Pressure (MAP)		bar			16			20
Flow Profile Sensivity Class					U0D0			
Verification scale interval		L			0.2			2
Indicating range		m³			999,999			999,999,9
Climatic environment					-10/70°C			

Performance Values

Nominal diameter (DN)	mm	40	50	65	80	100	150
	inches	1" ½	2" or 2" ½	2" ½ or 3"	3" or 4"	4" or 6"	6"
Starting flow*	l/h	22	32	35	50	70	90
Accuracy ± 2% from*	l/h	65	80	120	180	200	300
Accuracy ± 5% from*	l/h	45	60	100	120	150	200
Production ratio	l/h	200	250	315	315	315	315
Admissible peak flow (2 hrs. max.)**	m³/h	40	50	60	90	135	260
Max. temperature for short period	°C			60			
Max. admissible pressure	bar	16			20		
Cyble HF pulse weight	L			10			100

* Average values - ** Without impact of accuracy performances.

TYPICAL ACCURACY CURVE, FLOSTAR M QN 30 M³/H

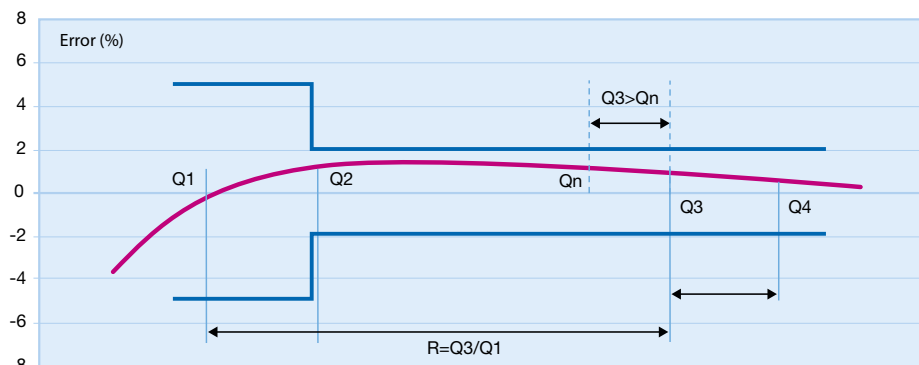

The dynamic range is defined by the Radio (R) between the permanent (Q3) and the minimum flowrate (Q1)

HEAD LOSS

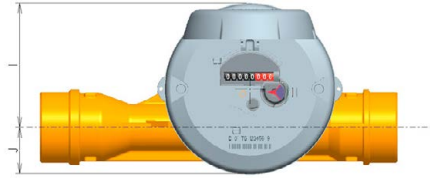
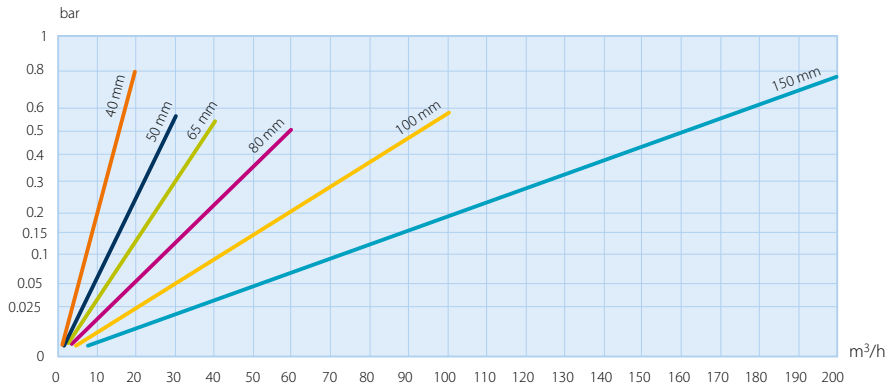

DN 40 and 50 (tot)

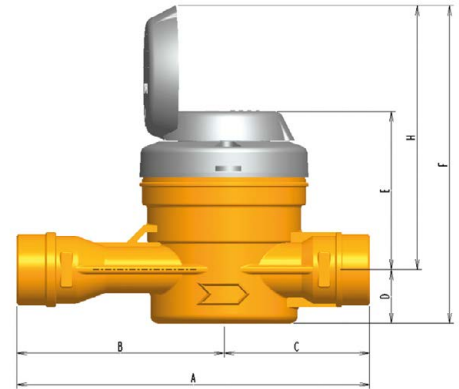

DN 40 and 50 (threaded)

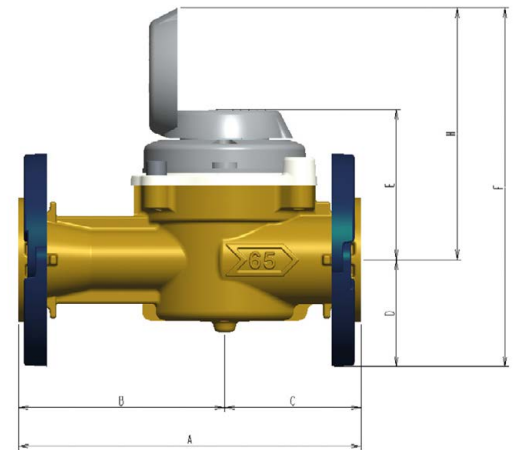

DN 50 up to 150 (flanged)

DIMENSIONS

Nominal diameter (DN)	mm	40	50	50	65	80	100	150
Meter connections		G2" B	G2" ½ B	Flanges	Mobile flanges			
				ISO PN10/16	compatible with major standards (ISO / DIN / ANSI / BS)			
A (length)	ISO mm	300	300	300	300	350	350	450*
	DIN mm	-	270	270	300	300	360	-
B	mm	175	175	175	180	200	184	240
C	mm	125	125	125	120	150	166	210
D	mm	45	48	83	92	100	110	144
E	mm	133	130	130	129	135	148	173
F	mm	189	189	224	232	246	269	328
H	mm	144	141	141	140	146	159	184
I	mm	104	104	104	118	171	198	236
J	mm	40	40	83	92	100	110	144
Weight	Kg	5,7	6	10	17	21	31,5	62

* Additional sleeve DN 150 length 50 mm available.

INSTALLATION REQUIREMENTS

- » Flostar M should be installed in the horizontal position with totalizer facing up for optimum performances.
- » Installation of a strainer upstream of the meter is recommended to protect the hydraulics from water-borne particles and debris. Please consult Itron's strainer brochure.
Flostar M DN 40 is supplied as standard with a strainer and can be fitted with standard non return valve on request).
- » According to the new European standard EN 14154, Flostar M execution doesn't require any straight length upstream/downstream of the meter (U0/D0 classification).

Easy sizing of the meter

Flostar M DN50, DN65 and DN80 can be supplied with bigger flanges and lengths to facilitate meter sizing to the real usage flow rates.