

Cast Iron Strainer Y-Style

Technical Guide W7.4

Y Strainers are suitable for a variety of fluid systems and are designed to filter solids. Mesh size determines strainer efficiency.



01.23 | W7.4 CAST IRON STRAINER Y-STYLE

Applications

Potable water

Raw water

Pump stations

Product Attributes

Flanged cast iron body

304 stainless steel screen

Easily serviced

Long life

SS Drain plug

Approvals/Standards

Flanged AS2124 T/E

Optional AS4087

We are the supply partner of choice for New Zealand's civil construction industry, specialising in water and infrastructure based solutions.

HYNDSwater

Y Strainers are suitable for a variety of fluid systems and are designed to filter solids. Mesh size determines strainer efficiency.

Applications

Strainers are most commonly fitted prior to back flow devices, valves and machinery where damage could occur from suspended solids in the water.

Features

- Flanged cast iron body
- 304 Stainless steel screen
- Screen mesh from 1.6mm
- Graphite steel compound gasket for long life
- Easily serviced
- Streamlined design for low head loss
- Vertical or horizontal installation
- Flanged to table D or E

Accessories

SS304 Perforated screen available upon request

Testing & Ratings

Rated to 16 Bar

Availability

Available in sizes DN40 > 600mm. Larger sizes and pressures available upon request

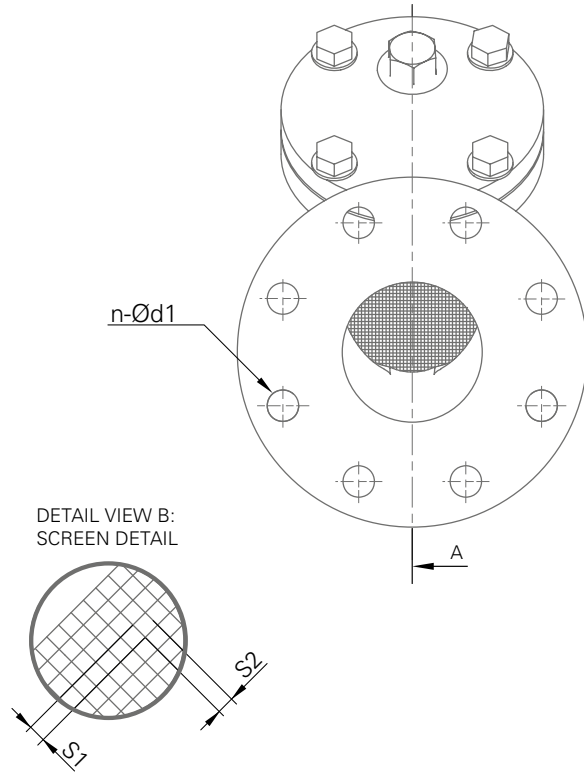

FIG. 1

TABLE 1

DN	NPS	FxF	b	ØD	ØD1	n-Ød1	h1	ØS	S1x S2	W	Weight (Kg)
40	1 ½"	200	14.2	135	98	4-14	135	46	1.2 x1.2	93	6.5
50	2"	225.4	15.8	150	114	4-18	150	54	1.2 x1.2	110	9.6
65	2 ½"	273	17.5	165	127	4-18	160	70	1.2 x1.2	135	12.3
80	3"	292	19	185	146	4-18	200	86	1.2 x1.2	155	17
100	4"	352.4	23.9	215	178	8-18	240	110	1.2 x1.2	205	28.1
125	5"	416	23.9	255	210	8-18	290	135	1.2 x1.2	225	40
150	6"	470	25.4	280	235	8-22	330	164	1.5 x1.7	260	48.9
200	8"	543	28.5	335	292	8-22	380	210	1.5 x1.7	318	82.3
250	10"	660.4	30.2	405	356	12-22	480	258	1.5 x1.7	400	127.3
300	12"	762	31.8	455	406	12-26	550	308	1.5 x1.7	454	200
350	14"	946.3	35	525	470	12-26	680	358	1.5 x1.7	560	320
400	16"	1079	36.6	580	521	12-26	780	408	1.5 x1.7	600	420
450	18"	1168	39.6	640	584	16-26	910	469	1.1 x1.1	832	620
500	20"	1275	42.9	705	641	16-26	968	520	1.1 x1.1	851	780
600	24"	1450	47.8	825	756	16-33	1160	623	1.1 x1.1	1066	1050

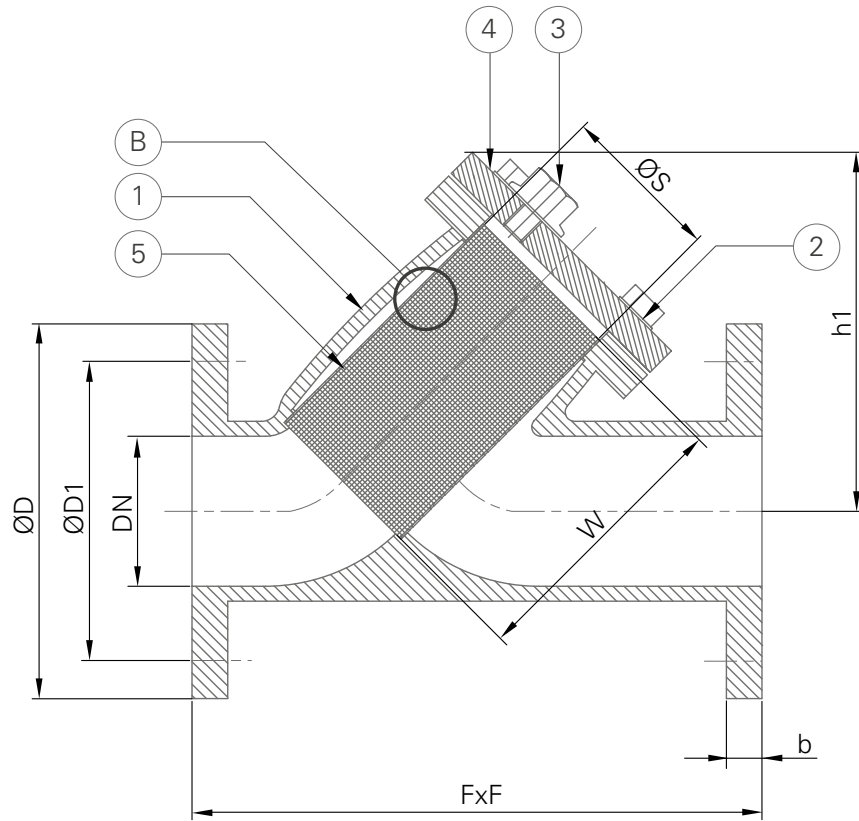

FIG. 2

TABLE 2

No	Description	Material
1	Body	Cast Iron
2	Gasket	Graphite Steel
3	Plug	SS304
4	Bonnet	Cast Iron
5	Screen	SS304 (woven wire mesh type)

Branches Nationwide *Support Office & Technical Services 0800 93 7473*

Disclaimer: While every effort has been made to ensure that the information in this document is correct and accurate, users of Hynds product or information within this document must make their own assessment of suitability for their particular application. Product dimensions are nominal only, and should be verified if critical to a particular installation. No warranty is either expressed, implied, or statutory made by Hynds unless expressly stated in any sale and purchase agreement entered into between Hynds and the user.