

# Uniprep™ Rotary Pipe End Peeling Tools

Technical Guide W7.12

The Uniprep range are peeling tools suitable for all SDR rated PE pipes. These tools feature a four edge tungsten scraping tip and lightweight die-cast aluminum body construction for reliable performance and ease of use.



05.24 | W7.12 UNIPREP ROTARY PIPE END PEELING TOOLS

## Applications

Peeling PE pipe prior to EF welding

Suitable for all SDR rated PE pipe

## Product Attributes

Spring loaded tip for irregular shaped pipe

4 sided tungsten peeling tip

Peel depth of 0.25mm ± 0.05mm

Supplied with steel tool box

## Quality

ISO 9001:2015

ISO 14001:2015

*We are the supply partner of choice for New Zealand's civil construction industry, specialising in water and infrastructure based solutions.*

**TABLE 1 Uniprep™ 4 Rotary Peeling Tool**

<b>Code</b>	<b>PEELUNI063250</b>
<b>Materials</b>	Mild Steel EN3A, Stainless Steel, Aluminum, Brass, Tungsten Carbide
<b>Finish</b>	Natural / Zinc passivate to mild steel
<b>Dimensions</b>	L. 360mm x W. 160mm x H. 290mm
<b>Depth of Cut</b>	0.3mm
<b>Max Peel Length</b>	165mm, feed per rotation 4.5mm
<b>Min-Max Pipe Size</b>	63-250mm All SDR Ratings
<b>Weight</b>	3.20kg (Excluding tool box) 7.44kg (Including tool box)



Note: PEELUNI063250 includes case.

**TABLE 2 Uniprep™ 2 Rotary Peeling Tool**

<b>Code</b>	<b>PEELUNI125500</b>
<b>Materials</b>	Mild Steel EN3A, Stainless Steel, Aluminum, Brass and Tungsten Carbide
<b>Finish</b>	Natural / Zinc passivate to mild steel
<b>Dimensions</b>	L. 420 x W. 160mm x H. 270mm
<b>Depth of Cut</b>	0.3mm, feed per rotation 4.5mm
<b>Max Peel Length</b>	175mm
<b>Min-Max Pipe Size</b>	125-500mm All SDR Ratings
<b>Weight</b>	3.8kg



Note: PEELUNI125500 includes case.

**TABLE 3 Uniprep™ 5 Rotary Peeling Tool**

<b>Code</b>	<b>PEELUNI450710</b>
<b>Materials</b>	Mild Steel EN3A, Stainless Steel, Aluminum, Brass and Tungsten Carbide
<b>Finish</b>	Natural / Zinc passivate to mild steel
<b>Dimensions</b>	L. 600 x W. 300mm x H. 340mm
<b>Depth of Cut</b>	0.3mm
<b>Max Peel Length</b>	345mm, feed per rotation 4mm
<b>Min-Max Pipe Size</b>	450-710mm All SDR Ratings
<b>Weight</b>	9.5kg (Excluding tool box), 18.5kg (Including tool box)



Note: PEELUNI450710 includes case.

### Replacement Blades:

**PEELUNIBLADE** Peeler Blade 4 sided for Uniprep

## Instructions for use:

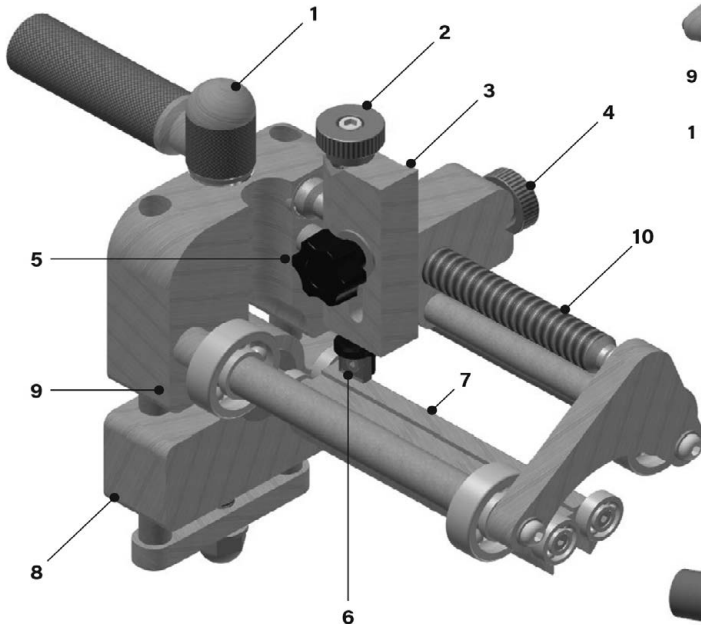

FIG. 1 Uniprep™ 4 Rotary Peeling Tool

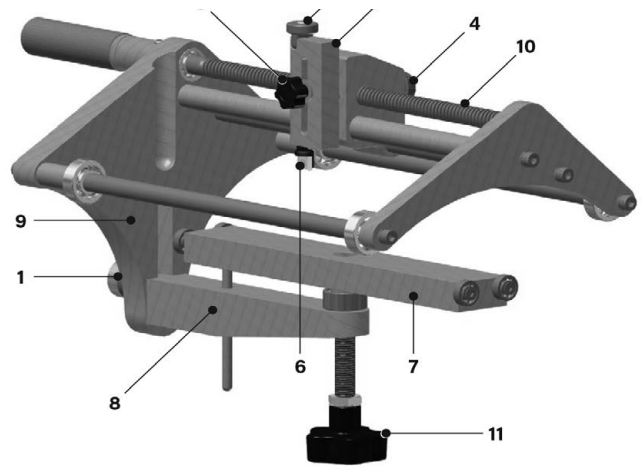

FIG. 2 Uniprep™ 5 Rotary Peeling Tool

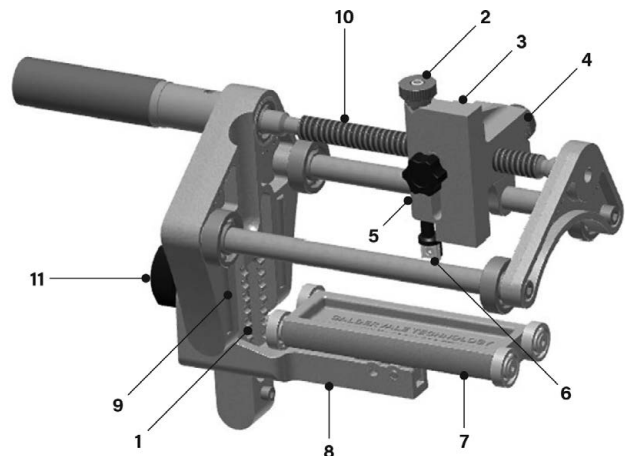

FIG. 3 Uniprep™ 2 Rotary Peeling Tool

1. Ensure that the pipe end is cut square (*No more than 2° out of square*), is free of burrs and the section to be prepared does not have any deep scores.
2. Mark the pipe outer wall at a point 50% of the length of the coupler plus 10mm.
3. Release the tool post cartridge (3) by loosening the tool post adjustment nut (5), position the tool post cartridge to its highest position and temporarily retighten (5).
4. Lower the underarm slide block (8) by turning the undercarriage adjustment & clamping thumbscrew (1).
5. Position the tool onto the pipe with the tool resting on the axle wheels and with the undercarriage (7) inside the bore of the pipe. The end of the pipe should touch the pipe stop (9).
6. Fix the tool in its operating position by adjusting the underarm adjustment clamping screw (1) until the undercarriage wheels are firmly against the inner wall of the pipe.
7. Slowly rotate the tool around the pipe 2 or 3 times to ensure that it is positioned correctly adjusting the underarm clamping screw (1) to ensure a secure but at the same time ease of rotation.

8. Pull and twist a quarter turn the quick release thumb nut (4) to allow the tool post carriage to move freely along the feed screw (10).
9. Remove the protection cap from the cutter (6) and position the cutter (6) above the mark previously made on the pipe indicating length of peel required, a further quarter turn of the thumb nut (4) will engage the feed screw-drive nut with the feed screw (10).
10. Pull & twist a quarter turn the cutter lifting thumb nut (2) to lift the cutter tip this also applies pressure via the tool tip spring.
11. Release the tool post adjustment nut (5) and slide the tool post down until the cutter is approximately 1mm from the pipe wall, now retighten the tool post adjustment nut (5) to fix the tool post in its correct operating position.
12. A further quarter turn of the cutter lifting thumb nut (2) will lower the cutter on to the pipe wall surface and the correct pressure will be applied to the tip (6) via the tool tip spring.
13. Rotate the tool around the pipe in a steady clockwise direction, the cutter will travel towards the pipe end removing a continuous strip of PE the process may be halted from time to time to remove surplus peel.

### Removal After Completion:

---

1. On completion, the peeled section should be inspected for areas of un-peeled pipe. If necessary the pipe can be peeled again.
2. To remove the peeler, loosen the tool post locking screw (5) and raise the tool post clear of the pipe and retighten (5). Loosen the underarm pressure screw (6) to release the undercarriage wheels and remove the peeler from the pipe. Refit the protective cover to the cutter tip when not in use.

**Branches Nationwide** Support Office & Technical Services 0800 93 7473

**Disclaimer:** While every effort has been made to ensure that the information in this document is correct and accurate, users of Hynds product or information within this document must make their own assessment of suitability for their particular application. Product dimensions are nominal only, and should be verified if critical to a particular installation. No warranty is either expressed, implied, or statutory made by Hynds unless expressly stated in any sale and purchase agreement entered into between Hynds and the user.