

Uniprep 7 Rotary Scrapping Tool

Technical Guide W7.11

This large diameter rotary scraping tool is for all SDR rated pipe between 630mm - 1200mm. The tool features a unique design with an expanding body that grips the internal diameter of the pipe to ensure peeling consistency.



05.24 | W7.11 UNIPREP 7 ROTARY SCRAPPING TOOL

Applications

Peeling PE pipe prior to EF welding

Product Attributes

Spring loaded cutting tip for irregular shaped pipe

Swivel cutting tip for increased pipe peel

Single or double peel cutting tip

Quality

ISO 9001:2015

ISO 14001:2015

We are the supply partner of choice for New Zealand's civil construction industry, specialising in water and infrastructure based solutions.

This easy to use tool, with a spring loaded peeling tip to accommodate irregular shaped pipe, has excellent performance characteristics.

Product features:

- Single or double peel cutting tip
- Lightweight aluminium body
- Spring loaded cutting tip for irregular shaped pipe
- Swivel cutting tip for increased pipe peel
- Easy to use shaft with crank handle
- 640mm peel length
- 0.25mm \pm 0.05mm cut depth
- Spare cutting blades available

Code	PEELUNI6301000
Max Dimensions (HxWxD)	1300 x 1360 x 1300mm
Min Dimensions (HxWxD)	760 x 875 x 1275mm
Weight	24kg
Finish	Natural / Zinc passivate to Aluminium / Stainless Steel / Mild Steel parts
Peel length	640mm
Depth of Cut	0.25mm \pm 0.05mm
Pipe Range	630mm – 1200mm

Replacement blade code:

PEELUNI7BLADE Peeler Blade Large Head Single Point for Uniprep 7

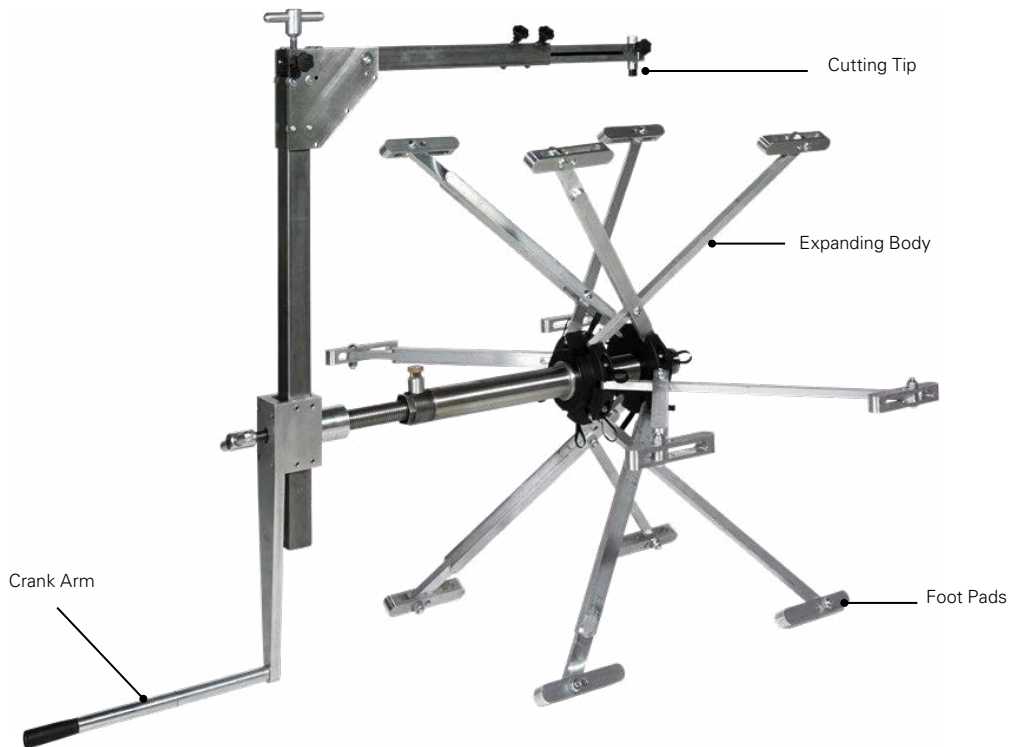

Operating Instructions:

Pipe Preparation:

1. Inspect the end of the pipe to be peeled to ensure it has no damage or deep scores and that it is externally clean.
2. Check that the pipe is round. Ovality should be reduced where possible. (*Re-round with re-rounding tool if required*).
3. Check that the end has been cut reasonably square.
4. Measure the insertion depth of the fitting and add on a minimum of 25mm (*35mm recommended*) to give a peeling witness. Mark the distance (*from furthest protruding face of pipe end*) and cross hatch that length of pipe with suitable pen.

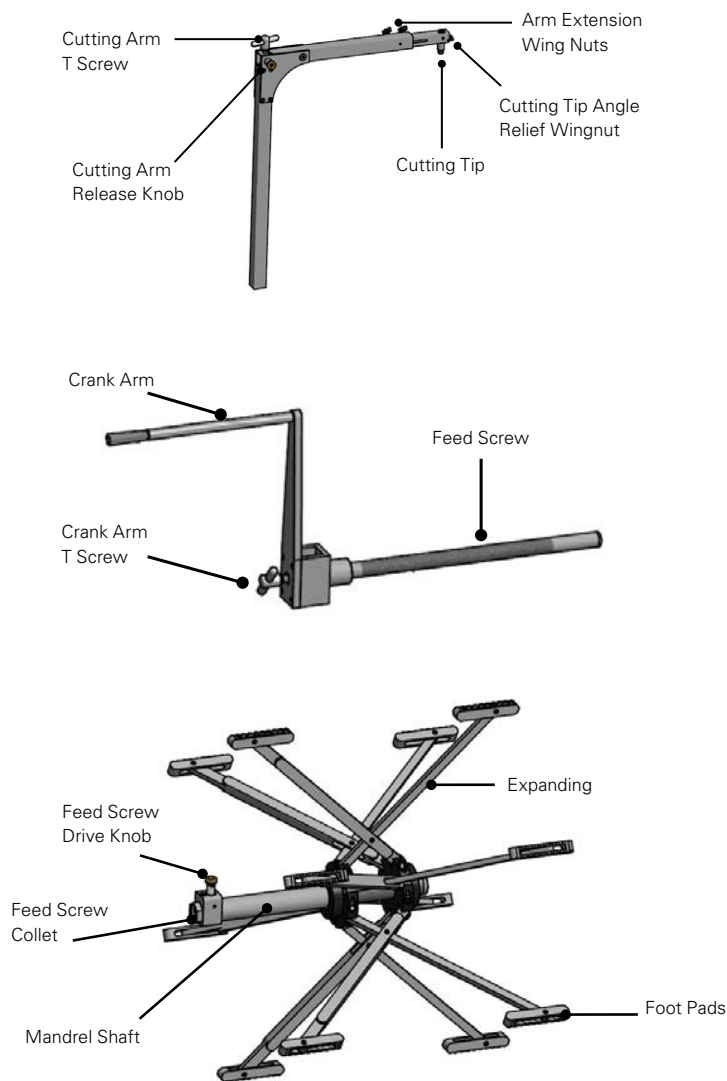

Using the Peeling Tool:

Firstly, check the expanding body, ensure all parts are present and nothing is loose or hanging off the tool.

1. Insert expanding body of the tool into pipe making sure the feet are past the point of any pipe end regression with the Feed Screw collet outermost.
2. Using supplied hex spanner locate on Feed Screw Collet expand the body by turning anti-clockwise until very tight, aiming to leave the Feed Screw Drive knob uppermost. Once tight, remove the spanner.
3. Quarter turn the feed screw drive knob to raise and disengage the thread driver (*if not already in position*). Next fully insert the feed screw and engage the feed screw driver by turning the feed screw drive knob a quarter turn. Unscrew the crank arm T screw ready to receive the peeling arm.
4. Raise the crank handle and insert the peeling arm. (*Note it is highly recommended to have the crank handle and peeling arm together in the same orientation to prevent injury from rotation of the tool*) Lower the peeling arm until the peeling tip is approximately 6-10mm from the pipe surface and lock in position with the crank arm T screw.
5. Mark the position of the blade tip on the pipe to identify the point when the telescopic peeling arm is retracted. This mark is used to identify when the feed screw is nearing the end of the thread and to prevent the peeling arm falling out and/or being damaged.
6. Loosen the two arm extension wing nuts, extend the peeling arm until it reaches the witness marking and lock in position.
7. Ensure the angle relief wing nut is tightened and does not allow the tool tip cartridge to pivot then release the cutting arm release knob and lower the spring-loaded peeling arm and blade onto the pipe.
8. Use the cutting arm T screw to adjust the spring tension until the load indicator is set on top of the cutting tip (*top of the cap head screw is flush with the round boss*).
9. Slowly turn the crank handle clockwise to rotate the cutter once round the pipe whilst continually keeping an eye on the load indicator, adjust the spring tension if required to apply the correct load at the pipes lowest spot.
10. Double check the Feed screw driver is engaged on the shaft then begin peeling until the mark made earlier is reached.
11. At the point where the mark is reached release the blade tension (*with the cutting arm T screw*), lift and lock the arm (*using the cutting arm release knob*).
12. Disengage the feed screw drive knob and slide the feed screw back in to the start position. Re-engage the feed screw drive knob.
13. Loosen the two wing nuts, retract the arm to line up with the end of the peel and lock in position.
14. Release the arm using the cutting arm release knob and adjust the spring tension until the load indicator is set. Continue to peel keeping an eye on the load indicator on the first rotation; adjust tension as necessary to set it for any pipe lowest spot.
15. If the pipe being peeled has any pipe end regression the Cutting Tip Angle Relief Wingnut needs to be loosened to allow the cutting tip to remain in full contact with the pipe and give a good peel.
Note: keeping an eye on the load indicator at this stage is essential to a good peel.
16. Continue until the peel is complete, cutter on to the pipe wall surface and the correct pressure will be applied to the tip (6) via the tool tip spring.

Removal After Completion:

1. Use the Cutting arm T screw to release blade spring tension.
2. Lift and lock peeling arm using cutter arm release knob.
3. Ensure the angle relief wing nut is tightened and does not allow the tool tip cartridge to pivot.
4. Release the feed screw drive knob and slide out feed screw and peeling arm and crank handle.
5. Separate peeling arm from crank handle using Crank Arm T Screw.
6. Use spanner clockwise to remove expanding body.
7. Ensure all parts are clean and dry.
8. Put all parts away in transport cases to protect them.

Branches Nationwide Support Office & Technical Services 0800 93 7473

Disclaimer: While every effort has been made to ensure that the information in this document is correct and accurate, users of Hynds product or information within this document must make their own assessment of suitability for their particular application. Product dimensions are nominal only, and should be verified if critical to a particular installation. No warranty is either expressed, implied, or statutory made by Hynds unless expressly stated in any sale and purchase agreement entered into between Hynds and the user.