

Calder Mains Restraining Clamp

Technical Guide W5.21

The Caldertech Mains Restraining Clamp will hold HDPE pipe securely during the weld process while also providing excellent re-rounding abilities for coiled pipe.

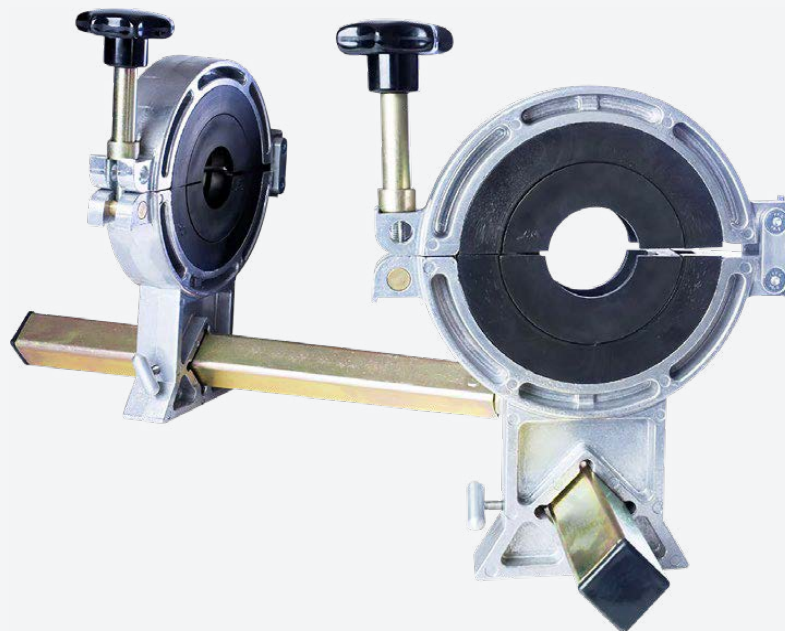

06.24 | W5.21 CALDER MAINS RESTRAINING CLAMP

Applications

Electrofusion

Buttfusion

Product Attributes

Suitable for PE pipe sizes 63mm-180mm

Available with straight or angle maker base

Standard kit comes with 63mm, 90mm, 125mm shells

Quality

ISO9001:2015

ISO14001:2015

We are the supply partner of choice for New Zealand's civil construction industry, specialising in water and infrastructure based solutions.

Made from lightweight die cast aluminum and steel, the mains clamp is quick to install and easy to use. Available with straight or angle maker base 22.5° increments.

Features

- Quick to install and easy to use
- Lightweight die cast aluminum
- Suitable for pipe sizes 63-180mm
- Injection moulded ABS reducing liner shells
- Available with straight or angle maker base
- Re-rounding capabilities.
- Standard kit comes with 63mm, 90mm, 125mm shells



TABLE 1 Alignment Clamp with Shells- Straight Base

Code	Pipe Range	Dimensions	Weight
CLAMP063180S	63-90-125-180mm	630 x 300 x 280mm	11.4kg

TABLE 2 Alignment Clamp with Shells- Angle Base

Code	Pipe Range	Dimensions	Weight
CLAMP063180SA	63-90-125-180mm	630 x 300 x 280mm	14kg

Operation Instructions

Operation Instructions for Angle Maker Base

- If an angled fitting is required an angle maker base should be used.
- The angle maker base should be set up by:
 1. First unscrewing the base screw with the provided Allen key.
 2. Mate the ends of the bases at the appropriate angle and replace the countersunk screw and tighten it until the base pieces do not move separately.

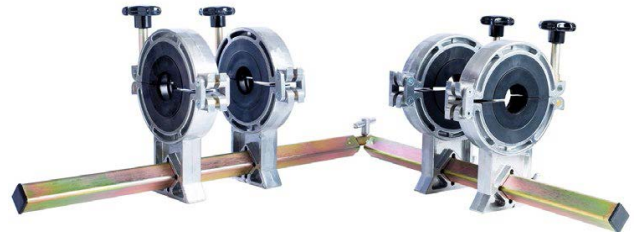

Operation Instructions for Clamps

1. Turn the clamping screws anti clockwise to release the top of the clamping ring.
2. Set the reduction liners to suit the pipe to be clamped (*using the provided Allen key unscrew any shells already in the clamp*).
3. Insert the required reduction liners fixing them in place using the Allen key provided.
4. Repeat above for any further rings to be used.
5. Select the appropriate box section base for the joint (*straight or angle maker*).
6. Insert the base selected into the diamond cut out in the bottom of the clamping rings to be used.
7. When the bottom of the clamp ring is in the correct/ preferred position turn the base locking screw clockwise to allow the bottom of the clamp ring to be fixed in place.
8. The pipe to be clamped can now be inserted into the clamps and the top of the clamping ring reattached using the clamping screws.
9. The clamping screws should be tightened to ensure the pipe cannot move relative to the clamping system.



Removal:

1. On completion of the jointing and cooling cycle, the clamp may be removed by releasing the Clamping screws, opening the clamp rings and lifting free.
2. Turn base locking screws anti-clockwise to release clamp from the box section base.

Branches Nationwide *Support Office & Technical Services 0800 93 7473*

Disclaimer: While every effort has been made to ensure that the information in this document is correct and accurate, users of Hynds product or information within this document must make their own assessment of suitability for their particular application. Product dimensions are nominal only, and should be verified if critical to a particular installation. No warranty is either expressed, implied, or statutory made by Hynds unless expressly stated in any sale and purchase agreement entered into between Hynds and the user.