

# Solenoid Control Valve

Technical Guide W4.61

The Singer Single Solenoid Control Valve is used for remote on/off control via SCADA, IoT, or local controller.

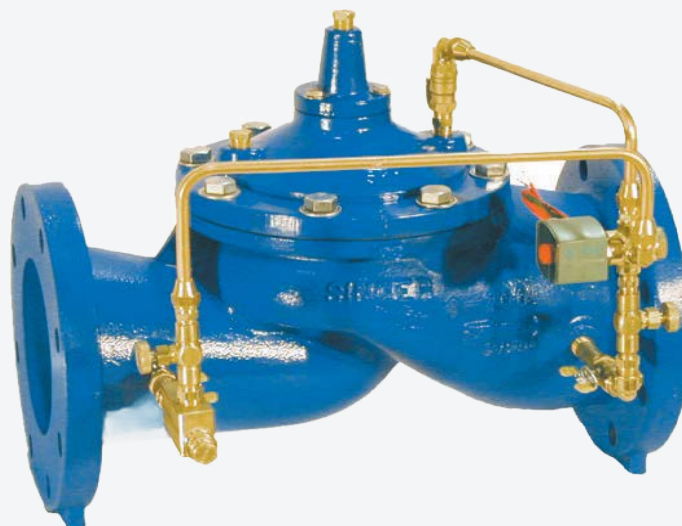

## Applications

Potable water  
Pressure control  
Municipal  
Mining Applications  
Irrigation Applications



**Licence Number:**  
WMK/SMK26726

## Product Attributes

Positive, drip-tight shut-off  
Simple, on-off operation  
Globe or angle style body

## Approvals/Standards

AS 5081:2008  
Flanges to AS/NZS 4087 Fig. B5  
Coating complies with AS/NZS 4158

## Quality:

ISO 9001:2015 Quality  
Management Systems

*We are the supply partner of choice for New Zealand's civil construction industry, specialising in water and infrastructure based solutions.*

The Solenoid Control Valve responds to an electrical signal to provide two-position (On/Off) operation. The solenoid either admits inlet pressure into the main valve operating chamber or releases pressure from the operating chamber. A variety of voltage options are available and solenoids can be normally open or normally closed.

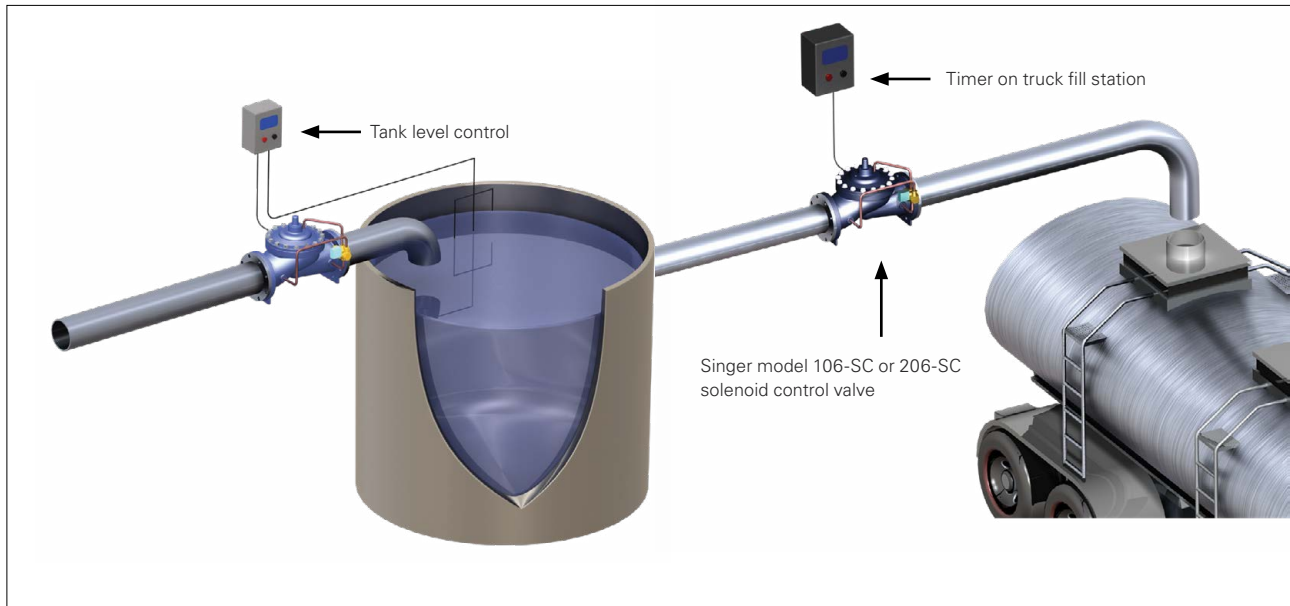

FIG. 1 Typical application

The solenoid control valve provides on-off position operation. The solenoid either admits inlet pressure into the main valve operating chamber or releases pressure from the operating chamber. The pilot system is usually piped to discharge at the valve outlet, but can be piped to discharge to drain (atmosphere). This valve is available either with the main valve closed when the solenoid is de-energised (NC - Normally Closed) or with the main valve open when the solenoid is de-energised (NO- Normally Open). (NC or NO refers to the main valve, not the solenoid.)

### STANDARD MATERIALS

Standard materials for pilot system components are:

- ASTM B62 bronze or ASTM B-16 brass
- Stainless steel trim
- Standard solenoid coil is rated as NEMA 1, 2, 3, 3S, 4 and 4X, combination general purpose and watertight
- Other voltages, ratings and constructions are available, consult with Hynds Water.

### SELECTION SUMMARY

1. Select the valve with sufficient capacity, using the allowable operating pressure drop across the valve.
2. If the outlet pressure is less than 35% of the inlet pressure, check for cavitation.
3. Ensure the maximum working pressure rating of the valve exceeds the maximum operating pressure.
4. Continuous, "C", service up to 6 m/s is generally suitable.
5. Provide system maximum and minimum operating pressures, electrical voltage, etc for correct solenoid selection.
6. If control fluid is from a separate source, provide Hynds Water with details.
  - a. For valve positioning - process control, see technical guide W4.60 Dual Solenoid Control Valve.
  - b. For two (2) stage opening or closing, consult with Hynds Water.
  - c. Most pilot functions may be combined with the model SC, consult Hynds Water.

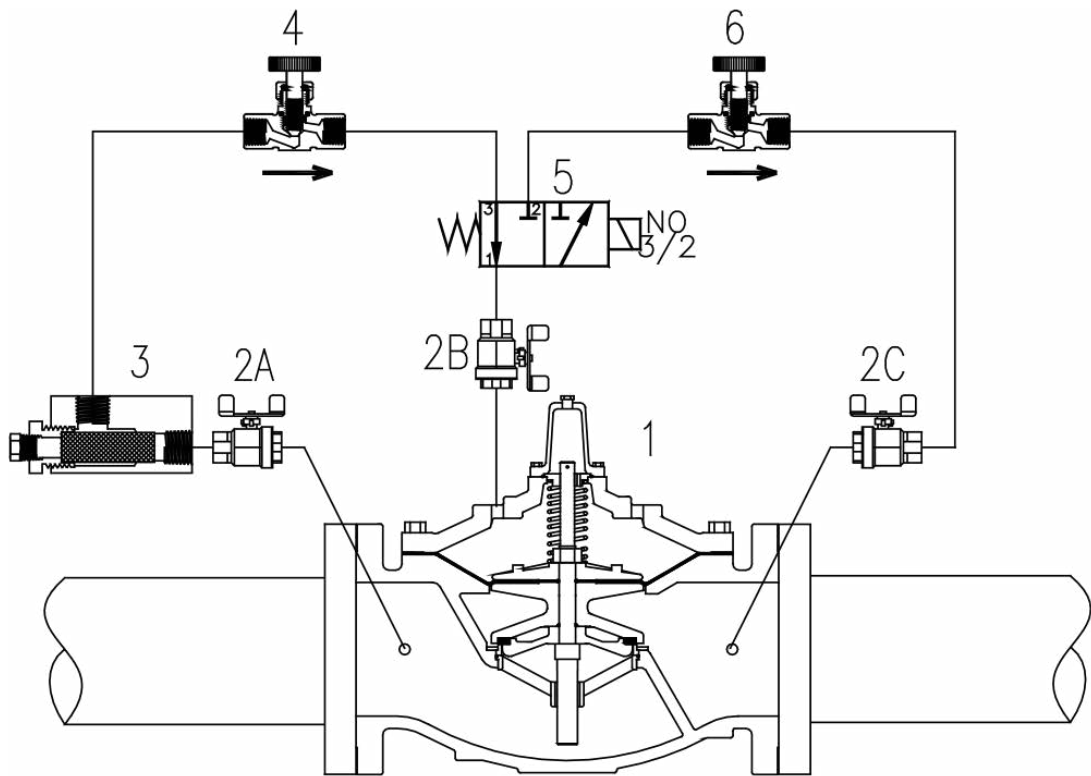

FIG. 2 Schematic A-0593C

### SCHEMATIC DRAWING

1. Main Valve - 106-PG or 206-PG
2. Isolating Valves - 2A, 2B, 2C - (optional on 80 mm and smaller).
3. Strainer - 40 mesh stainless steel screen
4. Closing Speed Control - model 852-B (optional on 80 mm and smaller).
5. Solenoid Pilot Valve - 3 way - 120 VAC / 60 Hz standard, other voltages available
6. Opening Speed Control - model 852-B (optional on 80 mm and smaller).

### ORDERING INSTRUCTIONS

Refer to the order form and ordering instructions.

1. Single Chamber (106) or (206)
2. Solenoid Voltage
3. Energise or de-energise solenoid to close main valve.

**Branches Nationwide** *Support Office & Technical Services 0800 93 7473*

**Disclaimer:** While every effort has been made to ensure that the information in this document is correct and accurate, users of Hynds product or information within this document must make their own assessment of suitability for their particular application. Product dimensions are nominal only, and should be verified if critical to a particular installation. No warranty is either expressed, implied, or statutory made by Hynds unless expressly stated in any sale and purchase agreement entered into between Hynds and the user.