

Flex Check Valve

Technical Guide W4.21

Flex Check for water applications.



10.21 | W4.21 FLEX CHECK VALVE

Applications

Potable water

Pump stations

Product Attributes

Ductile iron body

Non slam

Non clogging

Drip tight shut off

Low pressure drop

Approvals/Standards

AS4020 Approved

According to AS4794

Quality

ISO 9001:2008 Quality Management Standard

We are the supply partner of choice for New Zealand's civil construction industry, specialising in water and infrastructure based solutions.

HYNDSwater

Flex Check for water applications.

Features

- Non slam
- 100% sealing
- Non clogging
- Lower power consumption due to lower headloss
- Will not flutter like traditional swing check valves
- One moulded part (no maintenance)
- No counterweight needed
- Meets AS4794

Technical Data

- Size Range: DN80–DN600
- Pressure Classes: PN16 to AS47494
- Face to face: According to AS4794
- Temperature Range: 1°C to 80°C (higher on request)
- Flange Connection: AS 4087, Class 16
- Coating: AS 4020 approved epoxy

Benefits

The flex check valve offers efficiency and reliability due to simple but effective design. Low head loss is achieved by streamlined shape of body, disc and cover whilst offering 100% flow area with no restrictions. In addition water hammer and disc flutter is virtually eliminated and there is no need for a counterweight. This reduces power consumption, saving money and making it environmentally friendly.

The flex check valve short design stroke of 35° is much quicker compared with conventional swing check of 80–90°. This natural closing minimizes flow reversal and reduces slamming seen in conventional check valves.

This design also means that the disc is pushed up against body, even at low flow, eliminating disc “flutter” that can cause high wearing of shafts and bearings. Power savings are also achieved as the Flex Check does not require a weight to keep the disc in the flow or for closure of disc.

The heart of the Flex Check is the disc assembly and features:

- Special precision moulded EPDM one piece disc.
- Internal steel re-enforcement disc for positive closure.
- Nylon re-enforcement to maintain shape and strength.
- Raised soft sealing face for 100% sealing at low or high pressures. Eliminates metal to metal disc face wear.
- One moving part means no shafts, bearings or disc/body rings to maintain.
- Quick and easy field access.

TABLE 1

NO.	DESCRIPTION	MATERIAL
1	Body	Ductile Iron (GGG50)
2	Flapper	WCB + EPDM
3	Gasket	NBR
4	Bonnet	Ductile Iron (GGG50)
5	Pin	SS316
6	Bolt	SS316
7	Washers	SS316
8	Nuts	SS316

TABLE 2

DN	Fx F	b	b1	ØD	ØD1	ØD2	n-Ød1	Weight (Kg)
80	260	18	3	185	146	122	4-18	15
100	330	20	3	215	178	154	4-18	21
150	410	23	3	280	235	211	8-18	40
200	540	23	3	335	292	268	8-18	76
225	610	24	3	370	324	300	8-18	93
250	640	24	3	405	356	328	8-22	122
300	700	30	4	455	406	378	12-22	218
375	820	33	4	550	495	463	12-26	247
400	914	33	4	580	521	489	12-26	311
450	970	33	4	640	584	552	12-26	416
500	978	35	4	705	641	609	16-26	520
600	1220	42	5	825	756	720	16-30	790

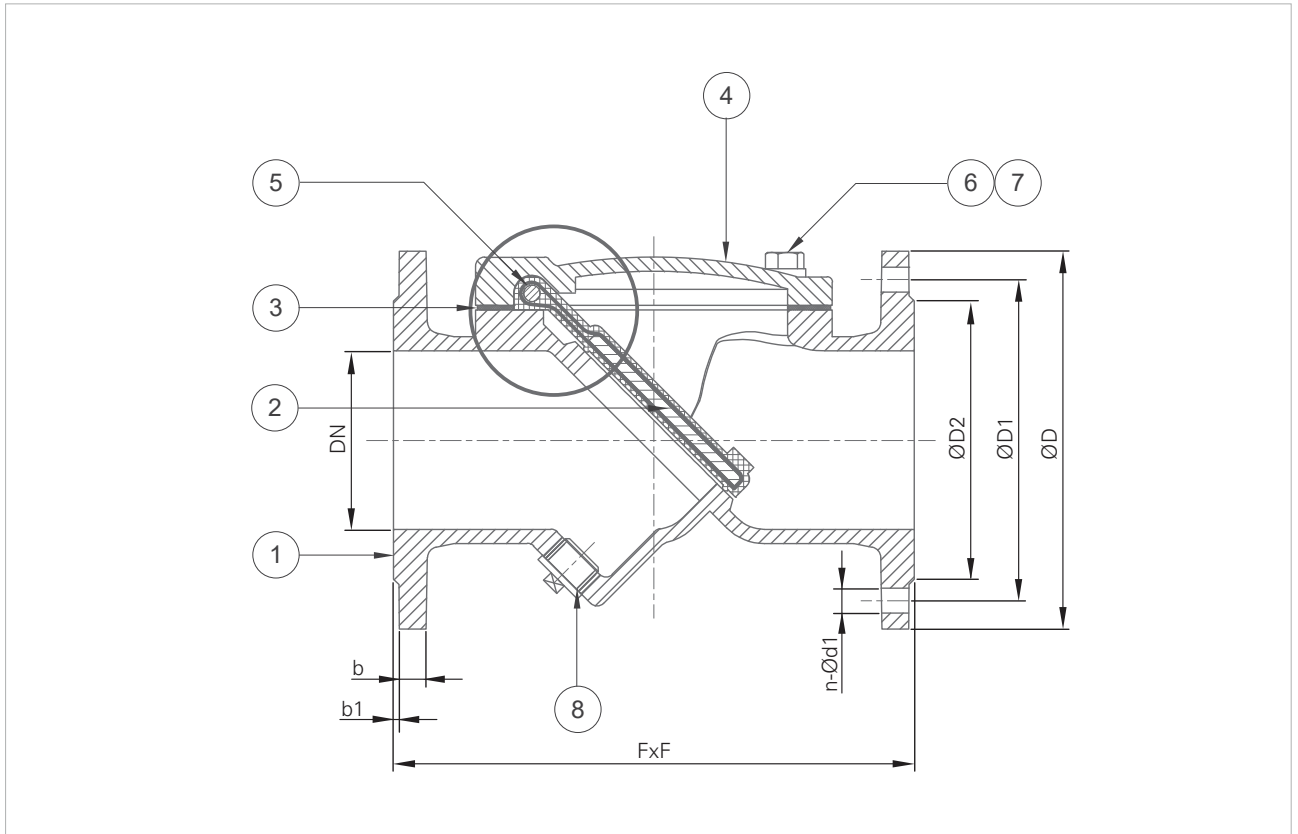

FIG. 1

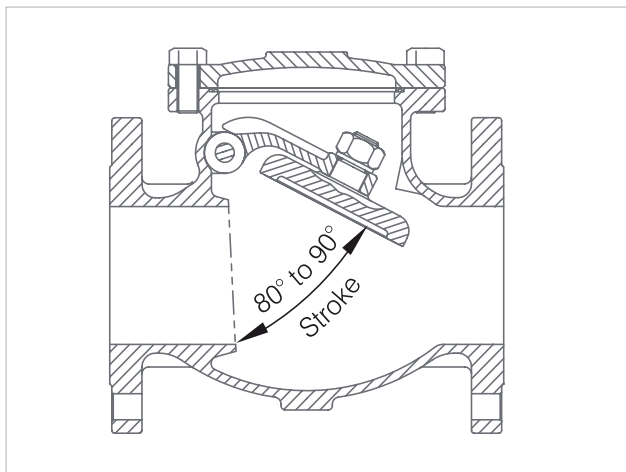

FIG. 2 Swing check

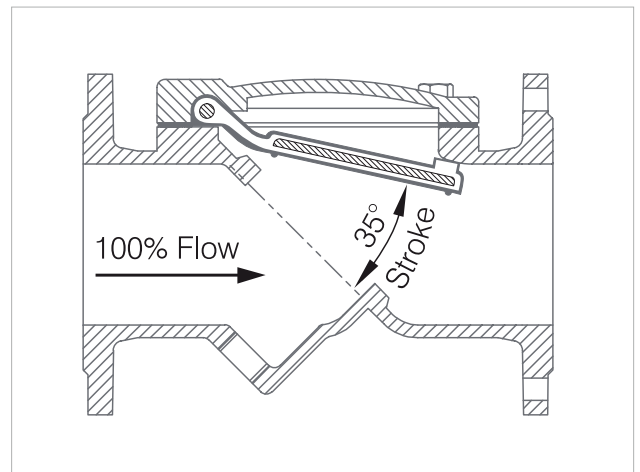

FIG. 3 Flex check valve

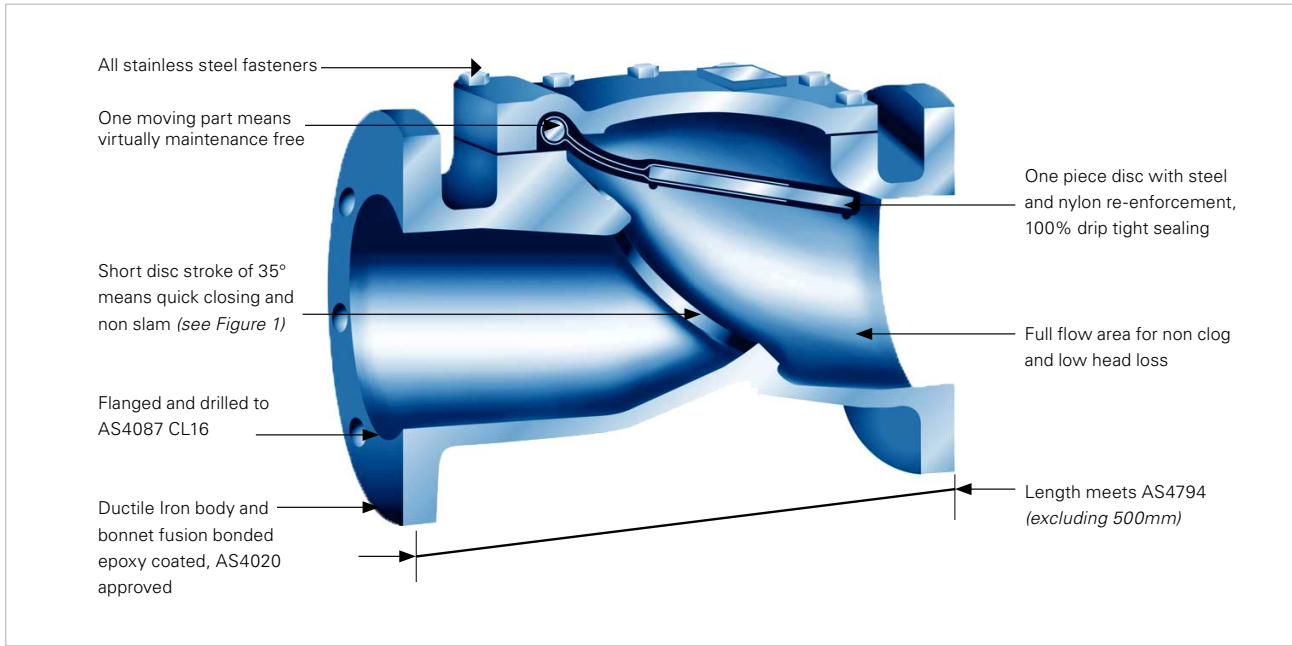

FIG. 4

Valve Headloss

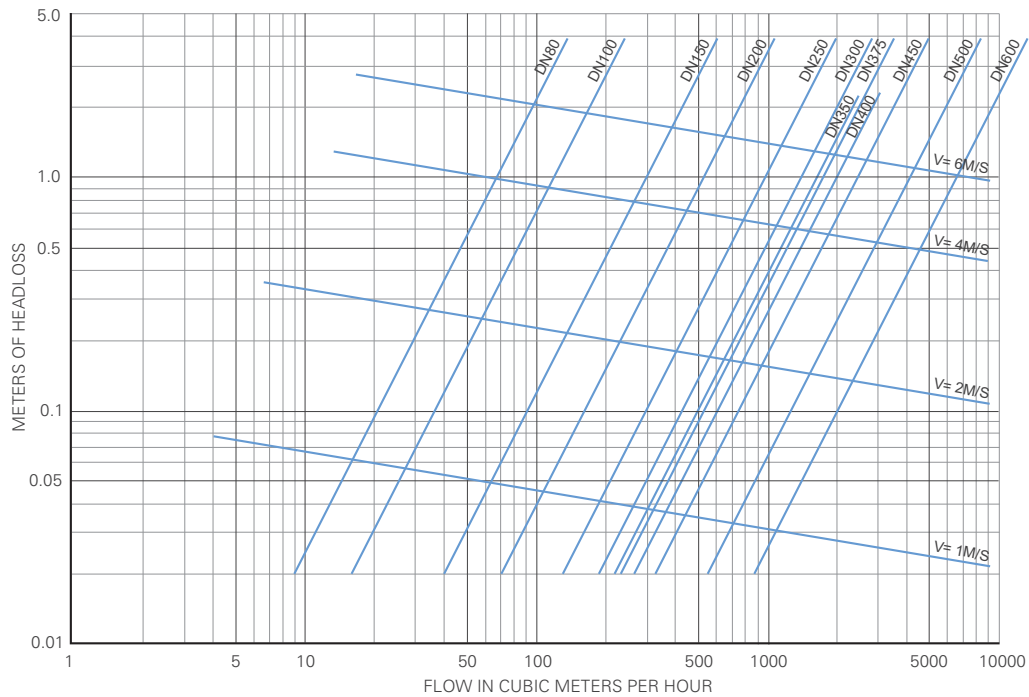

TABLE 3

Branches Nationwide Support Office & Technical Services 0800 93 7473

Disclaimer: While every effort has been made to ensure that the information in this document is correct and accurate, users of Hynds product or information within this document must make their own assessment of suitability for their particular application. Product dimensions are nominal only, and should be verified if critical to a particular installation. No warranty is either expressed, implied, or statutory made by Hynds unless expressly stated in any sale and purchase agreement entered into between Hynds and the user.