

Hawle Under-Pressure Tapping Tool

Technical Guide W7.2

Genuine Hawle Under-Pressure Tapping Tool. This is specifically designed to tap up to a 2" hole through a Haku Saddle for hydrant and branch connections.



06.22 | W72 DRILLING MACHINE

Applications

Under pressure tapping of steel, cast iron, AC or plastic pipes for watermain branch take offs.

Easy tapping through 2" threaded Haku saddles

Product Attributes

Easy and reliable hot tapping of watermain pipes under pressure

Swarf flushed out under pressure so no contamination of the watermain

Manual ratchet drilling system for remote applications

Online demonstration video available

Quality

ISO9001:2015 Quality Management

We are the supply partner of choice for New Zealand's civil construction industry, specialising in water and infrastructure based solutions.

The Hawle drilling machine is easy to use for making under pressure connections in watermains of differing pipe materials.

- When drilling under pressure, the swarf is washed out through a purpose - designed outlet (9)
- Drill bit is rotated by ratchet handle (1) and fed by feed wing nut (3)
- The ratchet is connected to the drill shaft with a simple locking device
- Pipe saddle adaptors and reducers are sealed with captivated rubber rings (8)
- Can be connected directly on to tapping saddle or isolation valve
- Total weight 17.5 kg

TABLE 1

Comes with the following drillbits and accessories

Twist drills for steel, CI and AC pipes:

Twist drill 1" - 24 Ø

Twist drill 1¼" - 29 Ø

Twist drill 1½" - 35 Ø

Twist drill 2" - 40 Ø

Cup drills for PVC pipes:

Cup drill 1" - 24 Ø

Cup drill 1¼" - 29 Ø

Cup drill 1½" - 35 Ø

Cup drill 2" - 40 Ø

Reducing adaptor with rubber seals

2" - 1"

2" - 1¼"

2" - 1½"

2" - 2½"

2" - 2" Equal adaptor with rubber seals

1 pc. Allen key size 5

2 pcs. C spanner for adaptor

Saddle blades for shut off:

1" - 1¼"

1½" - 2"

Complete in case Weight: 17,5 kg

TABLE 2 Hawle Under Pressure Tapping Tool Codes

Code	Name
TTUP	Under Pressure Tapping Tool for 1"-2" connections

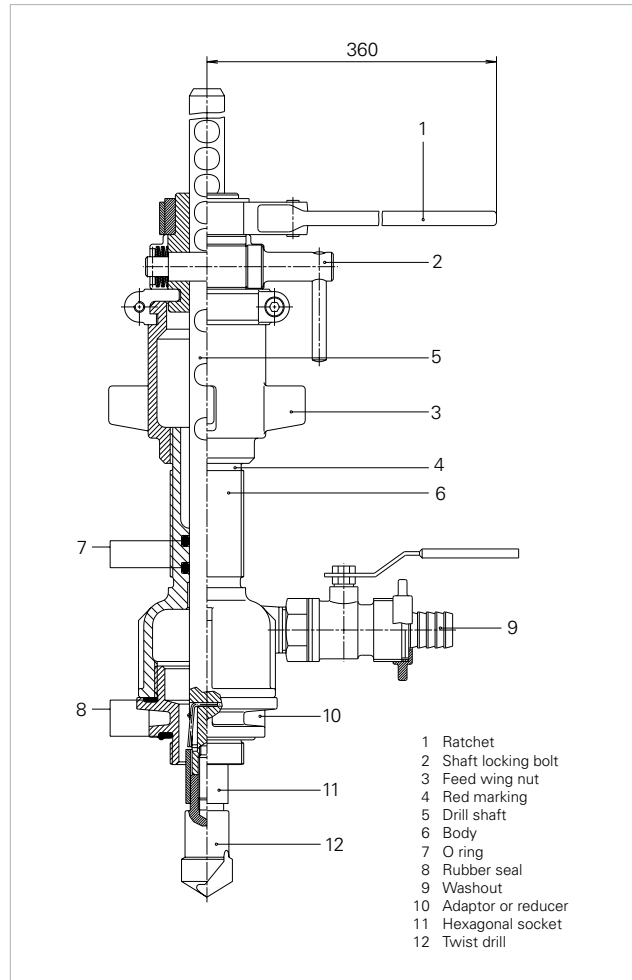

- 1 Ratchet
- 2 Shaft locking bolt
- 3 Feed wing nut
- 4 Red marking
- 5 Drill shaft
- 6 Body
- 7 O ring
- 8 Rubber seal
- 9 Washout
- 10 Adaptor or reducer
- 11 Hexagonal socket
- 12 Twist drill

FIG. 1



FIG. 2

Drilling Instruction

Video demo: <https://www.hygradewater.co.nz/product/drilling-machine/>

1. Secure appropriate tapping band to the pipe that is to be drilled, and (if required for under pressure tapping) attach a service valve to the tapping band. Ensure there will be enough clearance for a drill bit to pass through both tapping band and valve.
2. Choose the correct drill bit (1) and screw it onto the male threaded shaft. Push the Hex Sleeve (2) of the shaft over the hex of the drill bit.
3. Making sure the service valve is open for the drill to pass through, screw the Hawle drilling machine into the service valve or tapping band. Use one of the reducing bushes (4) if necessary.
4. Reset (unwind) the advancing nut (5) until you see the red warning marks (6) on the thread.
5. Without turning the advancing nut, loosen stop bolt (7) and push the drill shaft (3) until the drill bit makes contact with the pipe. Line up the notches on the shaft with the stop bolt (7) by rotating the shaft and withdrawing slightly it to the nearest notch to locate it. Secure the shaft by turning the stop bolt.
6. If you are drilling under pressure, open the valve on the side of the tapping machine.
7. Begin drilling by using the advancing nut (5) and rotating the shaft (3) with the supplied ratchet handle (8). Note, only use moderate force on the advancing nut. If the torque required to use the ratchet becomes high, back off the advancing nut and continue.
8. After drilling, reset the advancing nut to the red warning mark. If you are drilling under pressure, carefully release the stop bolt and the pressure from the tapped connection will push the drill bit and shaft clear of the service valve / tapping band. If the shaft does not move, it may be that the pressure is too low and you may pull the shaft clear by hand. Caution – keep clear of the shaft (3) during this process to avoid injury.
9. Close the service (attached to the tapping band), and disconnect the Hawle drilling machine.

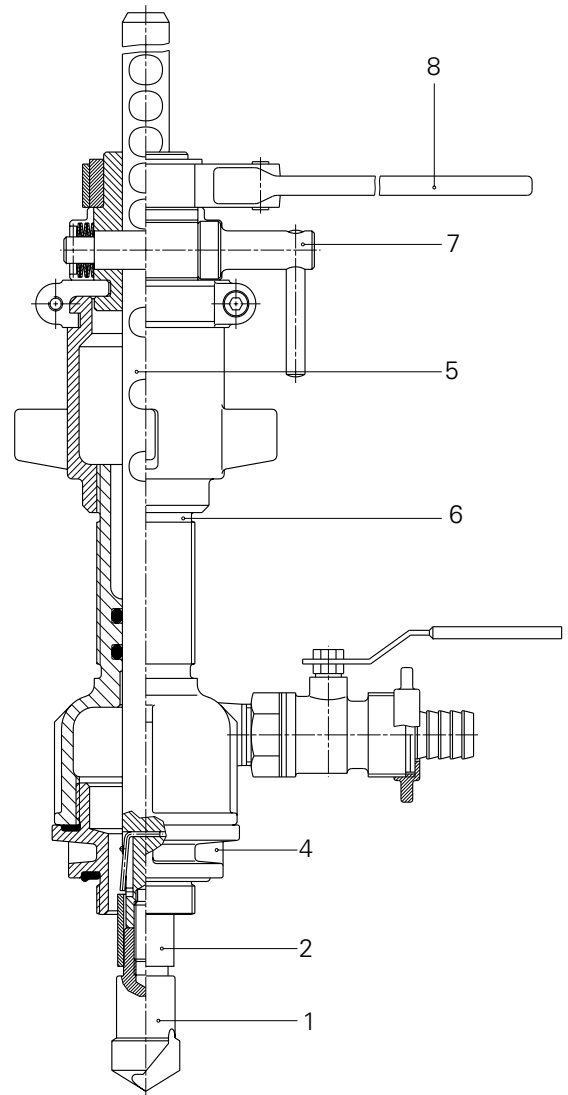

FIG. 3 Drilling machine assembly with drill bit for cast pipes

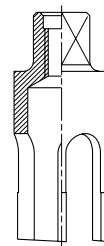

FIG. 4 Cup drill for PVC pipes

Branches Nationwide *Support Office & Technical Services 0800 93 7473*

Disclaimer: While every effort has been made to ensure that the information in this document is correct and accurate, users of Hynds product or information within this document must make their own assessment of suitability for their particular application. Product dimensions are nominal only, and should be verified if critical to a particular installation. No warranty is either expressed, implied, or statutory made by Hynds unless expressly stated in any sale and purchase agreement entered into between Hynds and the user.